

40 GHz Hybrid Fibre Wireless architecture : a new complementary approach for the introduction of interactive services

Authors : J. C. POINT (Thomson Broadcast Systems) and D. HARRISON (Thomson Multimedia)

THOMSON BROADCAST SYSTEMS
Rue du Clos Courtel
35517 CESSON-SEVIGNE Cédex

1. FOREWORD

Several **alternative** solutions can be envisaged for the delivery of future interactive services into the subscriber home :

- For cable operators, the best solution would be to provide a return path connection by using the existing cable networks. This solution presents the lowest incremental cost.
- Low frequency MMDS is an attractive solution for the Telecommunication Operators wishing to provide video services in that it offers a low cost means to provide additional broadcast services to the subscriber.
- In the case where highly interactive services, or professional services are envisaged, high frequency LMDS distribution, combined with optical transport, will provide an economically attractive solution in combination with HFC networks. A brief description of this last approach and preliminary cost analysis is provided in this paper.

2. SERVICES DEFINITION

2.1. *Consumer Multimedia services segmentation on cable TV*

All multimedia services can be segmented into three types :

- motivators (desirable features leading to consumers subscriptions);
- additional revenue generators (features not exciting enough to cause the initial purchase, but attract additional expenditure)
- finally churn inhibitors (services to which consumers will not pay for but to which they attach a value, and will lead them not to cancel their subscription).

Initial Purchase Motivators
Sports Hit movies Cheap telephony*
Additional Revenues Sources
VOD/NVOD On-line services Home shopping
Churn Inhibitors
News Special interest Local information

* : Cheap telephony is understood as telephony with the same level of quality as usual telephony; the consumer behaviour in front of a lower quality service with cut prices is still to be studied.

2.2. Professional service segmentation

The LMDS architecture allows the introduction of mixed professional/consumer applications on the same access network. Without going into the detail of these services, the following main drivers for LMDS deployment are :

- Leased links
- LAN interconnection
- Server downlink : in dense areas, we can imagine that there will be a significant number of small servers in the access network, taking advantage of the extra bandwidth available in the upstream.

2.3. Services requirements

The consumer and professional services described above can be segmented into several classes according to their respective traffic and quality of service requirements :

Level 1-Interactive services dedicated to broadcast services like NVOD, VOD, NOD, etc., and all the applications corresponding to burst type transmissions in the return path, consisting of small packets sent by the users, some applications like VOD requiring fast response time.

Level 2- General Variable Bit Rate (VBR) type or Available Bit Rate type services, which require medium bit rate in the upstream, and large bit rate in the downstream. The time response is not a stringent parameter in this case, but is important.

Level 3 - CBR (Constant Bit Rate) like services which include telephony or visiophony. These impose MAC layer, signalling and management adapted to these tough availability and bit rate constraints. The customer Set Top Box should support the interfaces with telephone or other equipment.

3. STANDARDISATION STATUS

3.1. Downstream channel:

In USA, the FCC has released the 27.5 to 28.35 GHz frequency band for downstream and the 31 to 31.3 GHz band for upstream. In Europe the CEPT recommends for high frequency MMDS the use of the 40.5 to 42.5 GHz frequency band for broadcast services.

The DVB transmission standard defined for these services is the same as that defined for digital satellite services (QPSK, MPEG2).

3.2. Interactive channel

The physical and MAC layer of the interactive LMDS network are currently under definition; a frozen specification is expected by the end of this year. As LMDS networks concern both residential and professional applications, several standardisation groups are working in parallel.

Both are considering a combination of TDMA/FDMA access methods.

The DVB specification draft is essentially finalised; a concern of the standardisation group is to remain compatible with the forthcoming HFC ETSI standards, as the LMDS network is assumed to be deployed in conjunction with the HFC network. Nevertheless the high bit rate capability both in downstream (38 Mb/s) and upstream (3 Mb/s) allows the introduction of professional services.

The DAVIC specification is currently being frozen; it is more focused on ATM transmission in both the downstream and upstream along with allowing a higher bit rate capability in the upstream.

4. SYSTEM OVERVIEW

4.1. Hybrid Fibre Coaxial/Wireless architecture

Figure 1 presents a generic HFC/W architecture

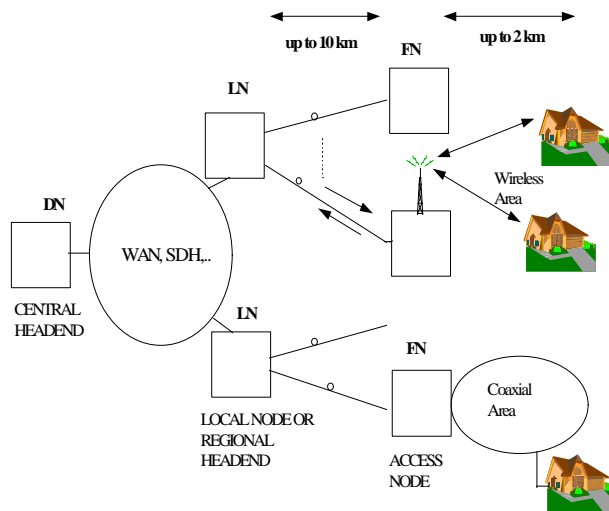

Figure 1 : HFC/W architecture

The Distribution Node (DN) or « Central Headend » concentrates all the programs and services to be broadcast in the network. The DN can serve a large city or a whole country.

The Local Node (LN) or Regional Headend (typically 100 000 subscribers); receives and reassembles the services dedicated to each Access area. The LN is the interface point for interactive services distribution and routing.

The Access Node (FN) is the interface point between optical and access network, which can be in our case either coaxial or wireless :

- The cable return channel bandwidth, which is typically 20 to 40 MHz, limits the coaxial area coverage population to 500 to 1000 subscribers.
- In the case of the LMDS network, rain attenuation limits the range of the system approximately to 1-2 km radius to ensure a service availability of 99.99 %, which corresponds to 1000 to 5000 subscriber per cell.

4.2. DVB standard description

The physical layer uses burst DQPSK modulation for upstream; the MAC layer uses a slotted TDMA access method to optimise the throughput. The slot size is 64 bytes, corresponding to an ATM packet with preamble, RS FEC and guard byte.

3 types of access method can be managed by the MAC layer : slotted ALOHA, RESERVATION, and CONSTANT BIT RATE. This permits a great flexibility for the applications support.

Channel models

It is not the purpose of the paper to go into the details of the upstream channel model as extensive work and measurements have already been made on the subject, but to give an overview of the type of disturbances which can exist on the cable and wireless areas.

CABLE

3 kinds of parasitic can limit the return channel throughput :

- gaussian noise, which is rarely the most important parameter; theoretically, the existing network can allow coaxial area size as large as 10000 subscribers (using QPSK modulation and at 3.088 Mb/s bit rate, which is the maximum specified in DVB).
- Ingress noise, which is due to poor cable or connectors shielding, especially close to the subscriber premises (an important part can come from the subscribers themselves); this kind of noise consists of both fixed frequency carriers parasitic and impulse noise; some bands (up to 10 MHz and around 27 MHz) are often difficult to use. This disturbance can be combated by network measurement and maintenance managed by the MAC layer (frequency change, retransmission)
- Impulse noise which is mainly due to power supply switching inside (poor contacts) and outside the network; these pulses are both filtered and clipped by the return path amplifiers and optical transmitters; the pulse statistics shows periods in the order of several μ s. It means that a significant part can be corrected by the RS code of each slot, thus allowing to recover the disturbed ATM packet.

40 GHz WIRELESS

Ingress noise and impulse noise don't appear to be a significant limitation; multipath is not important as long as engineering rules (direct line of sight, sufficient height) are respected.

The main factor is the effect of rain attenuation, which prevents in practice the use of cell radius greater than 2 km if 99.99 % service availability is required.

4.3. Traffic analysis

On the basis of the services described above, some traffic analysis which are out of the scope of this paper can be performed.

In the HFC case where areas of 500 to 1000 passings are considered, the upstream bandwidth can vary from 5-25 MHz in old networks to 5 - 65 MHz on more recent installations. The 5 - 10 MHz and 26-27 MHz bands are difficult to use, due to the different types of parasitic in these bands. According to these assumptions, a total upstream bandwidth of approximately 15 to 50 MHz is practically available. This would correspond to an available bit rate of 15 to 50 Mb/s, taking into account the modulation scheme defined in DVB (QPSK) and the MAC layer throughput.

This figure is more than sufficient for most consumer application scenarios, but can be limited for cases with extensive traffic and high uptake rate.

Moreover, the introduction of professional applications in some dense or industrial areas requires several hundred Mb/s upstream traffic per cell which can only be addressed using a HFW infrastructure.

An example of the downstream and upstream spectrum allocation is given in Figure 2 :

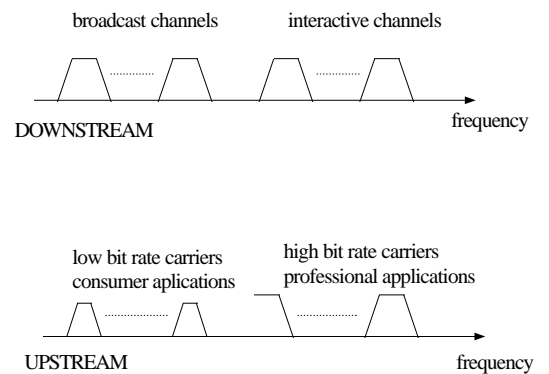

Figure 2 : Spectrum allocation

In Europe, the downstream frequency range would be 40.5 GHz - 42.5 GHz, shared between carriers transporting broadcast programs and data; the upstream frequency range is as not yet defined, but could be implemented in an extended band above 42.5 GHz; it can be dedicated, thanks to FDMA, both to low bit rate carriers (3Mb/s) for consumer and semi professional applications, and in the future to higher bit rate carriers dedicated to professional use.

4.4. Optical transport

The LN (Local Node) can serve hundreds of cells; in the full service network scenario, the LN throughput can be of several tens of Gb/s, thus making it difficult to imagine a wireless transport.

Bi - directional optical transport between the LN and Access Nodes appears as a simple, evolutive and reasonable cost solution.

The picture below shows a block diagram of downstream and upstream optical transport between the Local Node and the Access Node

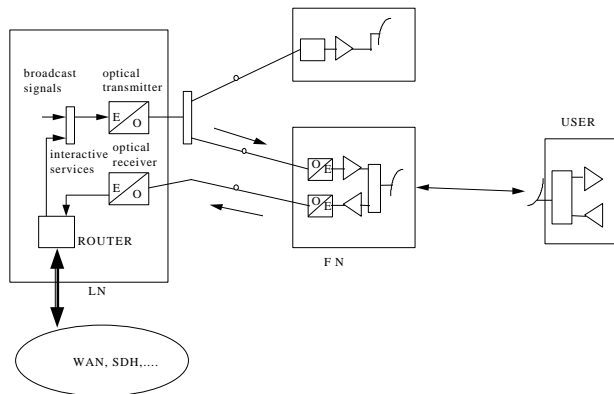

Figure 3 : Optical transport

2 possibilities can be envisaged :

The current available solution is to transport the downstream and upstream signals at low intermediate frequencies; in this case an IF to RF conversion has to be performed at the Access Node level :

The IF satellite band can be used for the downstream; for the upstream, if the LMDS is used in conjunction with a coaxial distribution, the 5 - 65 MHz band which is used for cable return path can be used; if a higher rate is to be transmitted, a larger band can be used (47 to 1000 MHz for example).

A future solution under investigation is the use of direct optical transport in the 40 GHz band. The issues with this solution are the price and system performance.

4.5. Cell configuration

In this microcell configuration , the installation and cable/tower infrastructure costs are of particular importance in the total system cost per subscriber..

In urban areas the existing infrastructure for mobile telephony could be applied to this new application; this can be shared in part or totally to install the 40 GHz optical and electrical equipment.

In the suburban and rural areas infrastructure possibilities include :

- use of existing mobile telephony infrastructure when possible;
- use of existing installations where supply power is available, street lamps for example.

Receiver mechanics

The 40 GHz headed Tx/Rx components should be placed as close as possible to the antenna. As the power amplifier output power is low, it is possible to envisage the integration of all components at the antenna input as shown below :

Figure 4 :

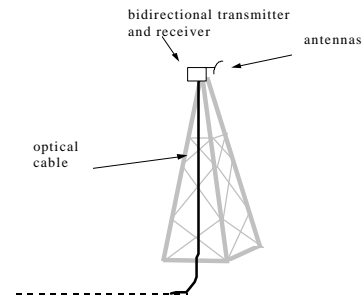

Figure 4 : Receiver mechanics

5. ECONOMICAL INTEREST

It is interesting to have an approximate idea of the Installed First Cost (IFC) of such a system and to compare this with a more standard HFC solution. The purpose is not to make a detailed comparison, but to make a first evaluation of the interest of an interactive high frequency MMDS system.

The diagram below represents the IFC per subscriber vs. uptake rate for HFC and bi-directional LMDS :

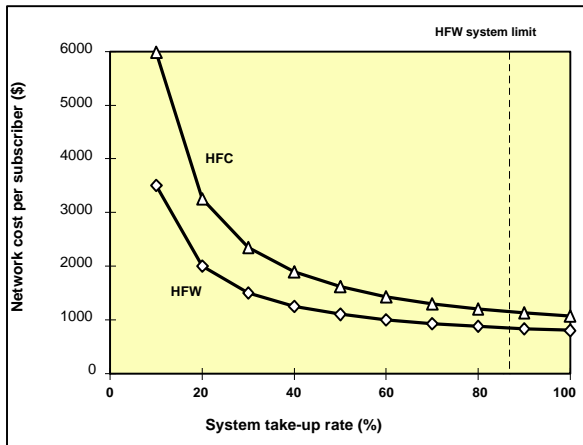

Figure 5 : Economical comparison

It should be noted that above a 70% uptake, this simple comparison shown above is no longer valid due to difficulties in obtaining very high levels of system penetration with the LMDS approach due to the line-of-sight transmission path requirement.

6. SOME EXAMPLES OF HFW IMPLEMENTATION

6.1. CATV network extensions in suburban areas

The coaxial distribution infrastructure cost in the HFC network becomes the most important issue in suburban areas, especially where underground cabling is required.

The benefit of a direct wireless cell feeding becomes obvious as shown in figure 4 ,as no transmodulation equipment is needed.

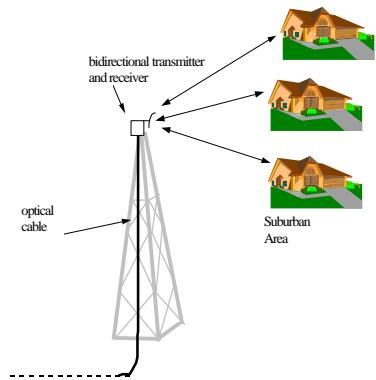

Figure 6 : Network extension

6.2. SMATV networks interconnections by LMDS

Some areas currently use SMATV or MATV networks extensively; if this local network is only usable in the VHF/UHF range, transmodulation from QPSK to QAM can be envisaged. These services can be combined with existing analogue broadcast programs or transmodulated satellite programs.

If the coaxial SMATV network can be used in the IF satellite frequency range, transmodulation of the LMDS programs is no longer necessary and the programs can be delivered as they are in QPSK

If not, the LMDS and satellite programs can be transmodulated to QAM for distribution in the VHF/UHF band

The 5 -65 MHz cable return channel bandwidth can be used in the SMATV local network upstream; a simple conversion to the 40 GHz band is made at the SMATV node location.

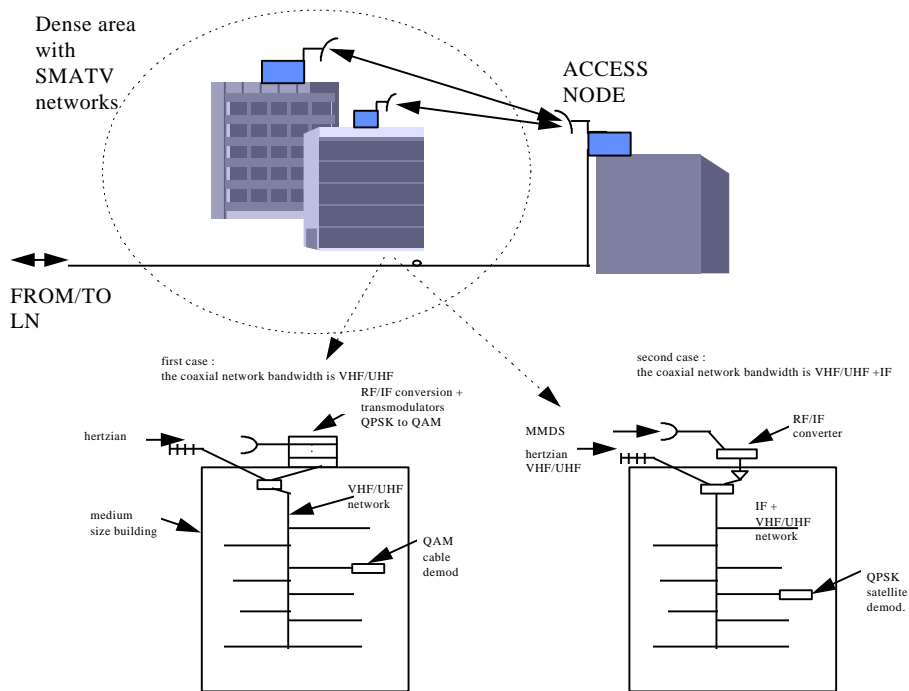

Figure 7 : SMATV networks connections

6.3. LMDS cells in urban areas : coverage of shadow areas

As previously explained, more than 70% subscriber coverage is difficult to achieve in these areas; 2 solutions can be implemented : either to install a repeater or to extend the LMDS cell with cable extension using RF to IF conversion.

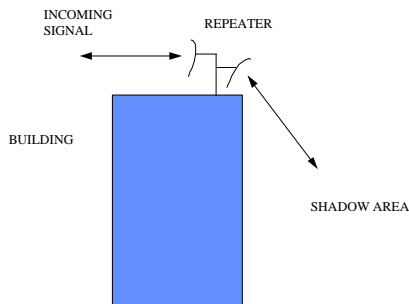

Figure 8 : LMDS repeater

7. CONCLUSION : TOWARDS A MIXED CABLE / LMDS ARCHITECTURE FOR INTERACTIVE SERVICES

The well know HFC architecture serving coaxial areas of 500-1000 homes is a viable and economical solution for the provision of interactive services in combination with analogue and digital broadcast services.

Higher frequency LMDS systems operate in either the 27.5-29.5 or 40.5-42.5 GHz frequency bands. These systems have limited range due to the effects of rain attenuation but have greater bandwidth capacity than lower frequency MMDS systems. Due to their short range and large bandwidth LMDS systems are well adapted to the broadband Hybrid Fibre Wireless (HFW) interactive services. Both consumer and Headend hardware is now becoming available in these frequency bands.

Finally, the figure below gives an example of full service network, based on HFC/HFW architecture.

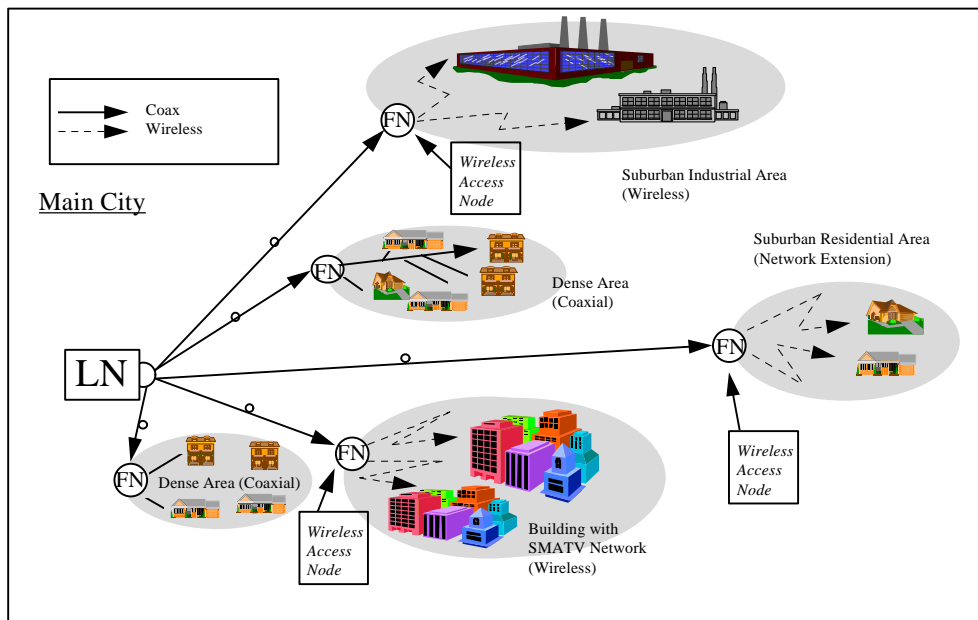

Figure 9 : Full service network.

8. GLOSSARY

LMDS	: LOCAL MULTIPOINT DISTRIBUTION SYSTEM
HFC	: HYBRID FIBRE COAXIAL
HFW	: HYBRID FIBRE WIRELESS
DN	: DISTRIBUTION NODE
LN	: LOCAL NODE OR REGIONAL HEADEND
FN	: FIBRE NODE OR ACCESS NODE
DVB	: DIGITAL VIDEO BROADCASTING
ETSI	: EUROPEAN TELECOMMUNICATIONS STANDARD INSTITUTE
FCC	: FEDERAL COMMUNICATION COMMISSION
RF	: RADIO FREQUENCY
IF	: INTERMEDIATE FREQUENCY
VHF/UHF	: VERY HIGH FREQUENCY/ ULTRA HIGH FREQUENCY
IFC	: INSTALLED FIRST COST